

WOOD

4 – 4 x 4 cedar posts cut to 16 1/2" lengths, for the legs. You can use treated posts, if you like.

4 – 2 x 6 cut to 60" lengths, for the seat (*Not shown in diagram*)

2 – 2 x 4 cut to 58" lengths, for the front and back rails of the frame

4 – 2 x 4 cut to 17 3/8" lengths, 2 for the side rails; and 2 for the joists of the frame

HARDWARE

16 – 1 5/8" exterior grade wood screws, for the pocket holes to build the frame

16 – 3 1/2" exterior grade wood screws, to attach legs to frame

24 – 2" exterior grade wood screws, to attach the seat boards

8 – 3/8" wood plugs

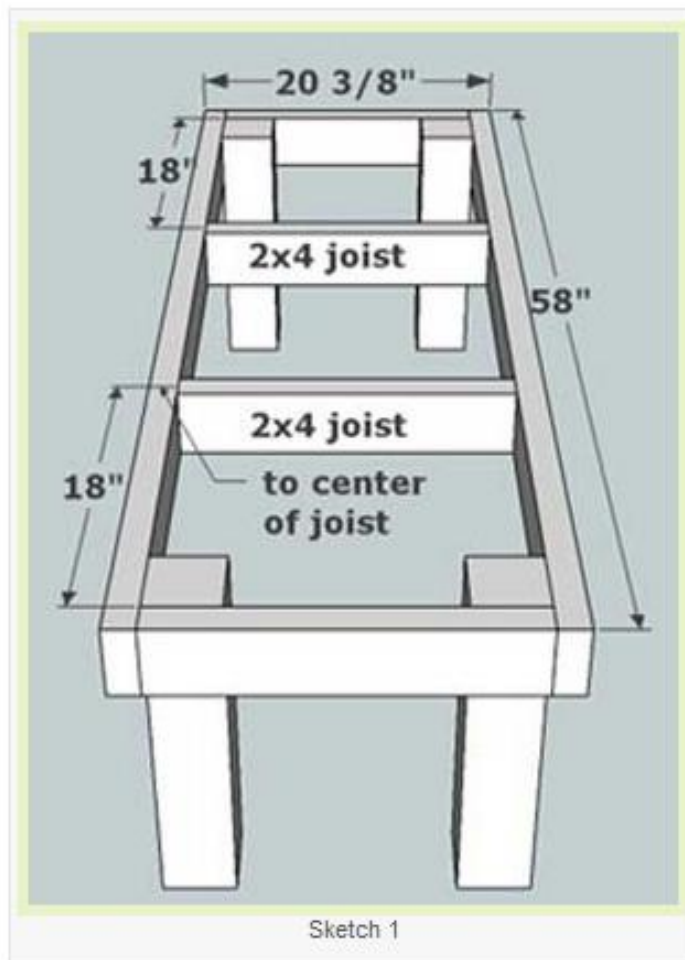

4 Questions

1. How many pieces of wood are we going to need?
2. About how wide will the bench be?
3. About how long will it be?
4. What does *joist* mean?